

## Open Trailers

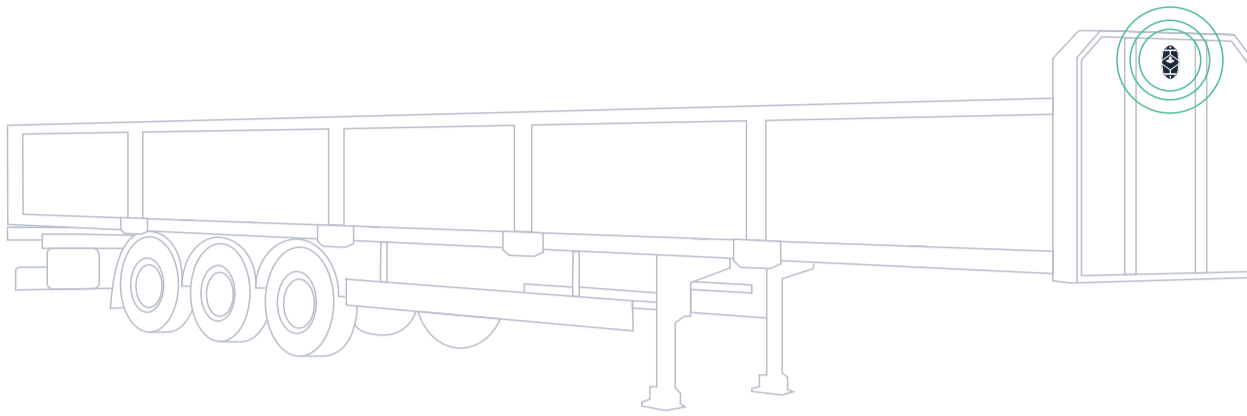

Do's	Dont's
<ul style="list-style-type: none"> <li>• As high as possible</li> <li>• Vertical installation (logo up)</li> <li>• On the front</li> <li>• Clear view on the sky</li> </ul>	<ul style="list-style-type: none"> <li>• Not on moving parts or close to the wheels because shocks might damage the tracker</li> <li>• Under the chassis because of bad signal</li> <li>• On the side where the tracker might get hit by other equipment</li> </ul>

## Flatbed trailers

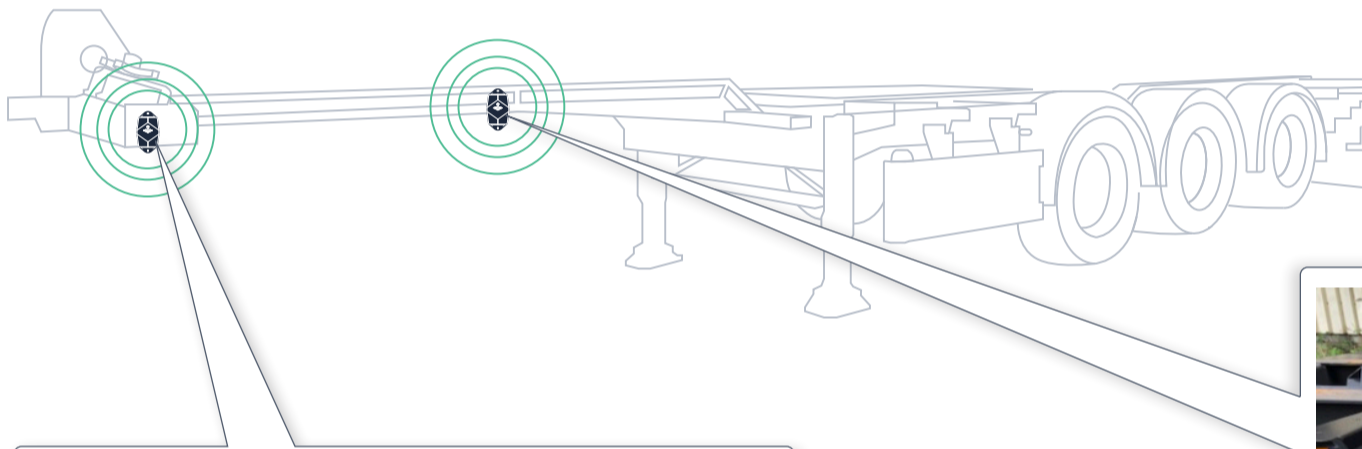

Do's	Dont's
<ul style="list-style-type: none"> <li>• As high as possible</li> <li>• Vertical installation (logo up)</li> <li>• On the front</li> <li>• On the side but protected by possible damage when parking the trailer.</li> </ul>	<ul style="list-style-type: none"> <li>• Under the chassis(bad signal)</li> <li>• Close to moving parts</li> <li>• Close to the wheels</li> </ul>

## Tarpaulin trailers

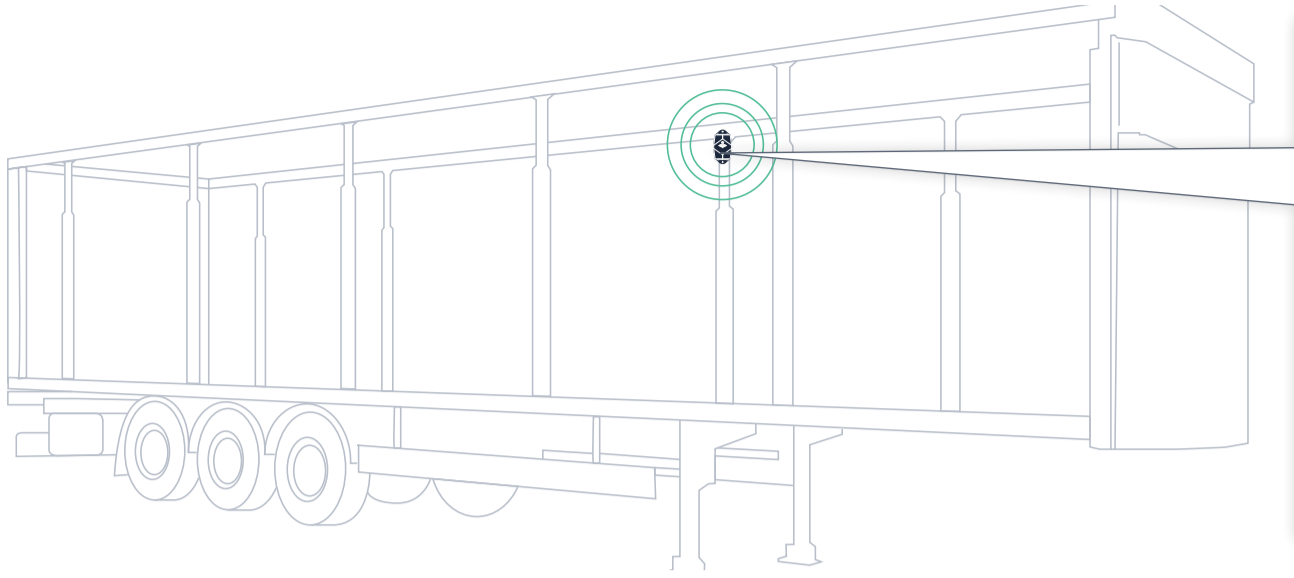

Do's	Dont's
<ul style="list-style-type: none"> <li>• As high as possible</li> <li>• Preferably vertical installation (logo up)</li> <li>• On the inside of the tarpaulin</li> </ul>	<ul style="list-style-type: none"> <li>• On the outside of the tarpaulin (tracker might get damaged)</li> <li>• Under the chassis (bad signal)</li> </ul>

## MAFI trailers

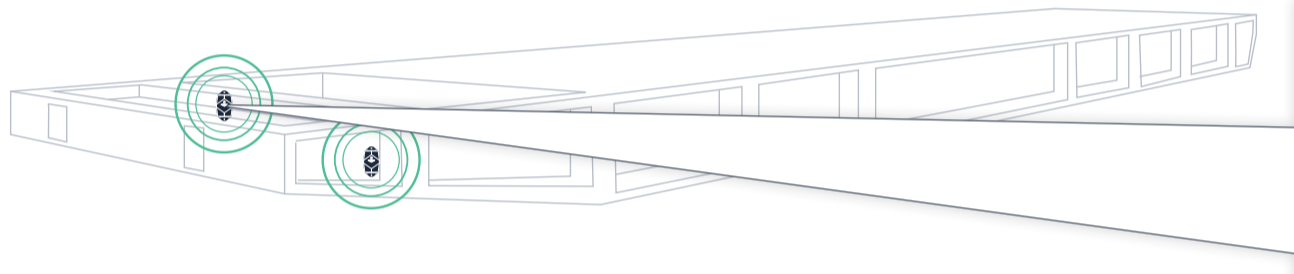

Do's	Dont's
<ul style="list-style-type: none"> <li>• Install the trackers on the front and the back</li> <li>• Installation on the sides is possible but protected from possible damage by other MAFIs.</li> <li>• Installion in beams is preferred so they are protected</li> </ul>	<ul style="list-style-type: none"> <li>• Do not install the trackers on the metal sleepers in between. The signal gets blocked when the MAFI is loaded</li> <li>• Do not instal the tracker on moving parts (wrong triggers such as OTM might get triggered and possible tracker damaging)</li> <li>• Under the chassis (bad signal)</li> </ul>